

Signal compression in radar using FPGA

Compresión de la señal de radar usando FPGA

Enrique Escamilla-Hernández^{1*}, Victor Kravchenko², Volodymyr Ponomaryov¹,
Gonzalo Duchén-Sánchez¹, David Hernández-Sánchez³

¹IPN ESIME Culhuacan, Av. Santa Ana 1000, 04430, Coyoacan, D.F., México.

²Institute of Radio Engineering and Electronics, Moscow, Russia.

³UAEH, CITIS, Mineral de la Reforma, 42082, Hidalgo, México.

(Recibido el 13 de junio de 2009. Aceptado el 9 de abril de 2010)

Abstract

We present the hardware implementation of radar real time processing procedures using a simple, fast technique based on FPGA (Field Programmable Gate Array) architecture. This processing includes different window procedures during pulse compression in synthetic aperture radar (SAR). The radar signal compression processing is realized using matched filter, and classical and novel window functions, where we focus on better solution for minimum values of side-lobes. The proposed architecture exploits the parallel computing resources of FPGA devices to achieve better computation speed. Experimental investigations have shown that the best results for pulse compression performance have been obtained using atomic functions, improving the performance of the radar system in the presence of noise, obtaining small degradation in range resolution. Implementation of the signal processing in the radar system for real time mode is discussed here and the effectiveness of the proposed hardware architecture has been justified.

----- *Keywords:* Pulse compression, synthetic aperture radar (SAR), atomic functions, windowing

Resumen

El presente artículo muestra la puesta en práctica de hardware para realizar el procesamiento en tiempo real de la señal de radar usando una técnica simple, rápida basada en arquitectura de FPGA (*Field Programmable Gate Array*). El proceso incluye diversos procedimientos de enventanado durante la compresión del pulso del radar de apertura sintética (SAR). El proceso de compresión de la señal de radar se hace con un filtro acoplado

* Autor de correspondencia: teléfono: + 52 + 55 + 5729 6000 Ext 73208, fax: + 52 + 55 + 5656 2058, correo electrónico: eescamillah@ipn.mx (E. Escamilla-Hernández)

que aplica funciones clásicas y nuevas de enventanado, donde nos centramos en obtener una mejor atenuación para los valores de lóbulos laterales. La arquitectura propuesta explota los recursos de computación paralela de los dispositivos FPGA para alcanzar una mejor velocidad de cómputo. Las investigaciones experimentales han demostrado que los mejores resultados para el funcionamiento de la compresión del pulso se han obtenido usando las funciones atómicas, mejorando el funcionamiento del sistema del radar en presencia de ruido, y consiguiendo una pequeña degradación en la resolución de rango. La puesta en práctica del tratamiento de señales en el sistema de radar en tiempo real se discute y se justifica la eficiencia de la arquitectura de hardware propuesta.

----- *Palabras clave:* Compresión del pulso, radar de apertura sintética (SAR), funciones atómicas, enventanado

Introduction

The quest for the resolving power of synthetic aperture radars (SAR) required in the remote sensing applications has two major consequences: first, their useful bandwidth should be increased in proportion with the resolution in range, that why, SARs are not only synthetic aperture radars, but also synthetic pulse radars; second, the length of the synthetic antenna (i.e. the duration of the acquired signal used for synthesizing one range line of the image) should be increased in proportion with the along-track resolution [1].

There are a number of different methods used in digital signal processing to improve the performance of the radar systems. Most of them are based on the procedures to distinguish different objects by the recognition of the properties of the target (humidity cartography, analysis, etc.) [1, 2]. Different criteria are applied in the radar signal processing, such as: maximization of Signal-to-Noise Ratio (SNR), Neumann-Pearson criterion in the target detection problem, minimum of mean square error, etc. [1, 2]. The pulse duration determines the resolution of the radar when it is measured in the signal propagation direction, so the shorter pulses permit to obtain better resolution. Restrictions on wave band channels and system frequency response impose the limits to thinner pulses; however these limitations can be improved using windowing procedure in processing to reduce the side-lobes distortion.

The selection of a radar signal is based on other important factors, among them, power considerations, maximum resolution and range distance. The search of such a waveform pulse that satisfies those criteria have been studied deeply [1 - 3]. Usually, the radar pulse with linear FM chirp has emerged as a convenient solution in comparison with other wave forms in SAR applications [2].

In order to decrease the probability of the false alarm, different window functions are used in the radar applications [4-6]. Such window functions are usually applied in time domain with the purpose to decrease the side lobes levels by processing the signal pulse permitting to decrease the possibility to confuse such a side lobe with a target that has less power or size. On the base of the theory of atomic functions (AF's), novel weighting functions (windows) are constructed demonstrating in numerous simulations their better performance in comparison classical windows in spectral signal processing [6].

Practical applications of radars demand real time mode in signal processing, for example based on the FPGA architecture. The FPGAs architecture presents advances in their capacity and performance; they have certainly emerged as leader implementation of digital systems. They have now captured the imagination of diverse communities, such as computer architects, researches looking from fingerprint recognition, image processing

or bioinformatics, among others [7]. In essence, FPGAs have high computational and memory bandwidth capabilities that are essential to real-time image/video processing systems. Because of such the features, there is an increasing interest in using FPGAs to solve real-time image/video processing problems. The purpose of this paper is to present the real time FPGA implementation in the radar signal processing during pulse compression and windowing procedures applying classical and AF functions.

Pulse compression radar

Pulse compression method is based on the usage of long especially modulated pulses that are transmitted, employing at radar receiver the matched filter to form short output pulse signals with improved SNR during pulse compression procedure. This pulse compression is being used extensively in the radars, permitting to get higher detection ranges due to increasing the transmitted energy, realization of high range resolution, and effective interference and jamming suppression. Different type of modulations in the pulse can be used, such as linear/nonlinear frequency modulation signals (chirp modulation) or discrete phase code modulation. Radar systems such as Doppler radar or SAR frequently use linear chirp modulation.

The linear signal FM chirp can be represented as:

$$S(t) = \begin{cases} S_0(t) \cos(\omega_0 t + \mu t^2 / 2), & |t| \leq \tau_p / 2, \\ 0, & \text{other } t \end{cases} \quad (1)$$

where, $S_0(t)$ is the signal amplitude, ω_0 - central frequency, μ - is a compression coefficient, and τ_p is pulse duration.

The usage of the long duration pulses in radar system with pulse compression processing gives several advantages:

- Transmission of long pulses gives an efficient usage of the average power capability of radar;

- Generation of high peak power signals is also avoided;
- Average radar power may be increased without increasing the pulse repetition frequency (PRF);
- Decreasing of the radar's unambiguous range can be achieved.

Better resolution capability in Doppler frequency shift is also obtained as a result of using long pulses. Additionally, the radar is less vulnerable to interfering signals that differ from the coded transmitted signal.

Usually, a matched filter is applied on the pulse compression stage, and multiple delays and correlators are used to cover the total range of interval of interest. The output of the matched filter is the compressed pulse accompanied by responses on the targets at other ranges that are called as time or range side lobes. The matched filter at the receiver makes the restoration of the initial waveform. It is well known that the impulse response $h(t)$ of such a filter is the complex conjugate of the time-reversed chirp $S(t)$:

$$h(t) = kS^*(-t + \tau_p) \quad (2)$$

where $S^*(-t + \tau_p)$ is the complex conjugate of the transmitted reference signal $S(t)$; so, the output of the matched filter can be written as $g(t)$:

$$g(t) = \frac{1}{T} \int_{-\tau_p/2}^{\tau_p/2} r(\tau) S^*(\tau - t) d\tau \quad (3)$$

where $r(t)$ is the received signal. In a discrete time case, the output function $g(n)$ can be written as:

$$g(n) = \frac{1}{N} \sum_{k=0}^{N-1} r(k) S^*(n - k) \quad (4)$$

Figure 1 shows the model for the pulse compression implementation. We used in this model for pulse compression four FIR filters with real and imaginary parts at the inputs. The signal

reference is also presented by real and imaginary parts. The real part of the pulse compression is calculated by summing the outputs of FIR 1 and FIR 2, and the imaginary part by adding FIR 3 and FIR 4 outputs. Finally, the absolute value (ABS) of the complex signal is calculated applying the ABS CORDIC algorithm, which lets to realize the pulse compression.

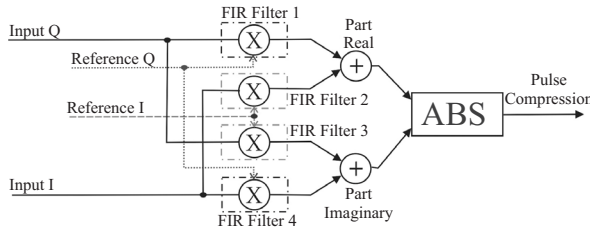

Figure 1 Model for pulse compression

Figure 2 exposes the pulse compression stages in matched filters. Additionally, the frequency weighting of the output signals is employed to reduce the side-lobes. Such side-lobes can result in a mismatched conditions and lead to a degradation of the output SNR of the matched filter. In the presence of Doppler frequency shifts, a bank of matched filters is required, where each a filter is matched to a different frequency then covering the band of expected Doppler frequency shifts.

Windowing

The radar applications demand to consider the target parameters that can be darkened by the adjacent lateral lobes of a very large (or powerful) target. So, the principal difficulty is how it can be distinguished a small target with respect to the lateral lobes of a large or more powerful target. The first lateral lobe of the uniform phantom has an attenuation of 13dB below the main lobe. The usage of the windows in the time domain essentially influences the effect of spectral lost [4].

Weighting function in time domain can be implemented by multiplying the FIR filter coefficients and then corrected radar signal.

In this paper, we make an evaluation of classical windows comparing its performance with some novel atomic windowing functions to reduce the effect of spectral lost [4 - 6].

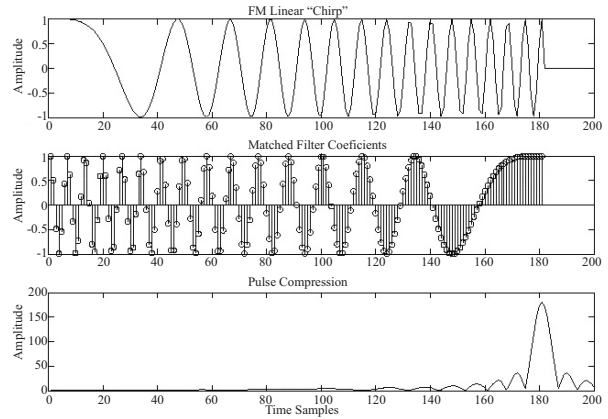

Figure 2 Pulse compression stages in the matched filter

The classical windows used in this work are: Hamming, Gauss, Hanning, Blackman, Blackman four-term, Kaiser-Bessel and Chebyshev windows [4, 5].

The atomic functions AF are widely used in different areas of computational physics and also in digital signal processing and image restoration [7 - 9], however until now they begin their usage in radar applications. It is well known that a main role in numerical approximation is played by algebraic and trigonometric (exponential) polynomials. Atomic functions let representing some polynomial using the translations function; whereas the translations property of other functions like “classical algebraic or trigonometric polynomials” cannot even form a polynomial of order zero (constant function).

Practical advantage of AF in comparison with classical functions is that the Fourier transforms for AF transforms are explicitly known [6].

By definition, AFs are compactly supported and they have infinitely differentiable solutions of the differential equations with shifted argument as shown in the following equation:

$$Lf(x) = \lambda \sum_{k=1}^M c(k)f(ax - b(k)), |a| > 1 \quad (5)$$

where L is a linear differential operator with constant coefficients. If $a=1$, and $b(k)=0$ the equation (5) becomes an ordinary differential one.

Similarly to linear differential equations with constant coefficients, these equations also can be effectively studied with the use of the Fourier transform. It was shown that AFs take intermediate place between splines and classical polynomials.

The simplest and most important AF $up(x)$ is generated by infinite convolutions of rectangular impulses with varying according to 2^k impulse duration, so the following representation on the base of the Fourier transform can be used [6]:

$$up(x) = \frac{1}{2\pi} \int_{-\infty}^{\infty} e^{jux} \prod_{k=1}^{\infty} \frac{\sin(u \cdot 2^{-k})}{u \cdot 2^{-k}} du, x \in [-1,1] \quad (6)$$

The extension of function with period 2π onto the whole real axis permits to represent the function $up(x)$ in form of a rapidly convergent Fourier series expression with respect to even harmonics.

Another important AF is $fup_N(x)$; these AF is the solution $y(x)$ of the following differential equation [6, 9]:

$$y'(x) = 2 \sum_{k=0}^{n+2} (C_{n+1}^k - C_{n+1}^{k-1})y \quad (7)$$

$$(2x - k \times 2^{-n-1} + (n + 2) \times 2^{-n-2})$$

and is represented in the form of such a Fourier transform

$$fup_N(x) = \frac{1}{2\pi} \int_{-\infty}^{\infty} e^{jux} \left(\frac{\sin(u/2)}{u/2} \right)^N \prod_{k=1}^{\infty} \frac{\sin(u \cdot 2^{-k})}{u \cdot 2^{-k}} du \quad (8)$$

The function $fup_N(x)$ is evaluated in the range $[-(N+2)/2, (N+2)/2]$

The function $fup_N(x)$ is positive and even for all N. Derivative of $fup_N(x)$ can be expressed via the function $fup_{N-1}(x)$ [6, 9]. Functions $fup_N(x)$ are the so-called fractional components of $up(x)$ [7, 9]. This means that the function $up(x)$ can be expanded into the convolution of finite length from functions $fup_N(x)$ for any N. This property makes formulas for atomic functions to be flexible in numerical applications.

Another AF $\Xi_n(x)$ used in windowing procedures that is the generalization of the $up(x)$ function can be written as:

$$\Xi_n(x) = \frac{1}{2\pi} \int_{-\infty}^{\infty} e^{jux} \prod_{k=1}^{\infty} \left(\frac{\sin u(n+1)^{-k}}{u(n+1)^{-k}} \right)^n du, x \in [-1,1] \quad (9)$$

Finally, the AF $gk(x)$ that is also applied as a window is presented as follows [6]:

$$g_k(x) = \frac{1}{2\pi} \int_{-\infty}^{\infty} F_k(u) e^{(-iux)} du, x \in [-1,1] \quad (10)$$

$$F_k(u) = \prod_{j=1}^{\infty} \frac{\frac{k^2}{1-\cos(2k/3)} [\cos(2u3^{-j}) - \cos(2k/3)]}{k^2 - u^2 9^{(1-j)}} \quad (11)$$

Hardware implementation

High gate count and switching speed of modern FPGA is enabling high data-rate DSP processing to be performed without resorting to ASIC technology. Static RAM based FPGA also enable solutions to be reprogrammable. Then the soft solutions offer flexibility, which is an important attribute of a modern radar system. Consequently, FPGA implementations are attractive in applications where their relatively high unit cost and power consumption are not critical [10].

Modern phased array radar relies heavily on DSP to achieve high levels of system performance and flexibility, but FPGAs represent an opportunity to achieve the required processing performance in real time (such as multiplications, sums, square root, etc), and also reprogrammability that is

an important aim of the radar systems, thereby enabling simplified system development and upgrade.

In this work, it has been tested the performance of the FPGAs to generate the radar signal and realize the pulse radar compression.

We employed the Kit Altera FPGA to realize the linear signal FM chirp.

The model applied to generate the pulse is shown in figure 3 employing Kit Altera. Two ROM blocks are used to form the values for real and imaginary parts of a pulse. A cycle counter is applied to design repetitive radar pulse and two DAC are used to convert digital to analog form.

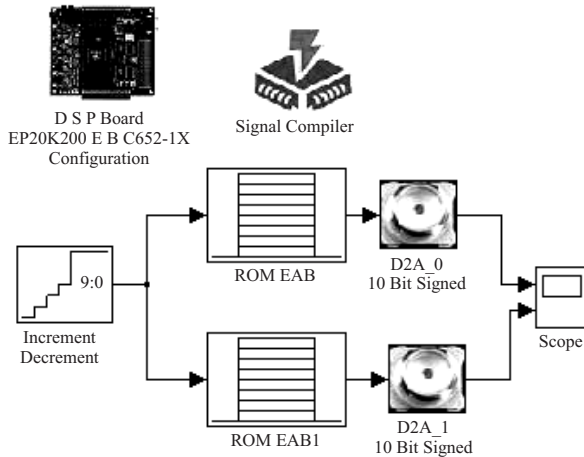

Figure 3 Radar pulse model

The matched filter implementation on FPGA lets eliminating special chips previously needed. We have tested the performance of such a model in the FPGA Xilinx model VIRTEX II XC2V3000. The hardware Xtreme DSP II and programming software: Matlab 6.5, Simulink, System Generator and FUSE made possible to implement on the FPGA the pulse compression processing in real time mode. Analyzing different approaches, we finally found the final FPGA system structure proposed in figure 4.

The main advantages of proposed structure (the software and FPGA hardware) is the facility whereupon we can easily change the parameters

of each a block of the system. It is required in some applications to increase the precision of the system, and then increasing number of bits can be realized in each used block, that let us flexibility to adjust the parameters of the system, and therefore better solutions.

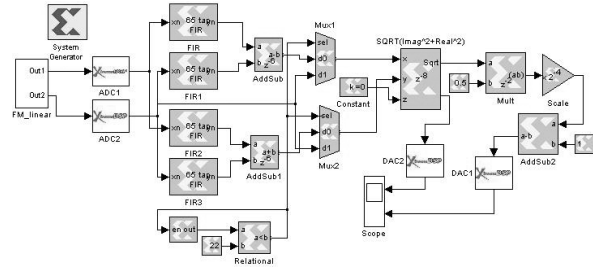

Figure 4 Hardware FPGA model

The number of taps in each FIR filter shown in figure 1 was 65, realizing the matched filter as it is shown in figure 4. The SQRT block presented in figure 4 calculates the magnitude of the output of matched filter. CORDIC algorithm explained in the next section is applied to calculate such a magnitude.

Cordic Algorithms

The algorithm CORDIC (Coordinate Rotation Digital Computer) is an iterative technique widely known and studied to evaluate many operations, such as: basic arithmetical and mathematical functions. The CORDIC method can be employed in two different modes, known as the rotation and vectoring mode. The coordinate components of a vector and an angle of rotation are given in the rotation mode, so the coordinate components of the original vector are computed after rotation through a given angle. In the case of vectoring mode, the coordinate components of a vector are given and the magnitude and angular argument of the original vector are computed [11].

Here, we analyze vectoring mode to approach the square root value. The CORDIC rotator rotates the vector of the input by any angle necessary to align the resulting vector with x axis. The result of the operation vectoring is a rotation angle and the scaled magnitude of the original

vector (component x of the result). The function vectoring works trying to reduce to the minimum y component value of the residual vector in each rotation. The sign of the residual vector y is used to know the direction of the next rotation. If the value of the angle is initialized with zero, it has to contain the angle crossed at the end of the iterations. According to the model for the pulse compression implementation it is necessary to calculate the square root value. The equations to calculate magnitude value of the complex signal during the pulse compression are defined by iterative equations presented below:

$$\begin{aligned} x_{n+1} &= x_n - d_n y_n 2^{-n} \\ y_{n+1} &= y_n + d_n x_n 2^{-n} \end{aligned} \quad (12)$$

Here: $d_n = \begin{cases} -1 & \text{if } y_n \geq 0 \\ +1 & \text{if } y_n < 0 \end{cases}$, and finally

$$\begin{aligned} x_n &= A_n \sqrt{x_o^2 + y_o^2} \quad ; A_n \\ &= \prod_n \sqrt{1 + 2^{-2j}} \quad ; y_n = 0 \end{aligned} \quad (13)$$

Performance of different windows

During the implementation of the proposed procedures, we used the radar with the next parameters: signal is linear FM (Chirp), frequency deviation (Δf) is 9.375MHz, the pulse width (τ_p) is 3.2 μ s, sampling frequency is 40MHz [3, 8].

The performance of different windows has been widely studied in the literature [4 - 6, 9], where the researchers are especially interesting in improving its sidelobe behavior. Parameters values in pulse radar processing have been obtained during application of different classical and novel windows_based on AF, the most significant parameter values, which have been found, are shown in table 1. These parameters are known as: window gain, side lobe level, main lobe width, and the coefficient of noise performance [4 - 6]:

$$\text{window gain, } K_{gain} = 0.5 \int_{-0.5}^{0.5} W(t) dt \quad (14)$$

where $W(t)$ represents the model of the window used;

side lobe level is determined as:

$$10 \log \left(\max_k \left| \frac{S_{com}(t_k)}{S_{com}(t=0)} \right|^2 \right) \quad (15)$$

and main lobe width at 6dB level is defined according to following equation:

$$10 \log \left(\left| \frac{S_{com}(t=0)}{S_{com}(t)} \right|^2 \right) = 6 \text{ dB} \quad (16)$$

where $S_{com}(t)$ is compressed signal after window processing.

Finally, the coefficient of noise performance is the relation indicated as follows:

$$\frac{SNR_{window}}{SNR_{rectangular}} \quad (17)$$

As it is observed in table 1, after applying different windows the best classical window performance for radar pulse compression gives the Hamming window, these is due to: 0.54 gain value, -32dB level of the side lobes, and a main lobe width of 239.2 η sec. One can see that the main lobe width is near double than the 129 η sec of rectangular window main lobe width.

So, comparing each one of all applied windows with Hamming window one, we can conclude the following.

The function $Fup_4(x)$ offers smaller attenuation in the amplitude of the main lobe, as well as a lower main lobe width in comparison with the Hamming window. Because the attenuation of the side lobes is one of the most important parameters, so the function $up(x)$ can be employed with advantages since it shows a better performance. Additionally, other windows already designed [6] have been implemented and applied in radar

processing, a comparison performance of them let us take the next conclusions: the best result can be obtained using novel window, such as

the $Fup_4(x) \cdot D_3(x)$, where significantly better results are in the side lobes attenuation, as well as in the smaller attenuation criteria.

Table 1 Parameters values for different windows in radar pulse compression

<i>Windows</i>	<i>Gain</i>	<i>Side lobe level (dB)</i>	<i>Main lobe width at -6dB (ηsec)</i>	<i>Coefficient of performance in noise presence</i>
Rectangular	1	-13,7	129,5	1
Hamming	0,5398	-32	239,2	0,7527
Blackman	0,4199	-31,3	350	0,6096
Blackman-Harris	0,3588	-30,1	477,1	0,5395
Kaiser-Bessel $\beta=3.5$	0,6403	-26,7	220,2	0,7534
$fup_3(x)$	0,3871	-30,7	368,7	0,4823
$fup_4(x)$	0,5797	-25,7	208	0,4542
$up(x)$	0,5	-31,4	249,1	0,6359
$fup_4^2(x) \cdot B^2(x)$	0,4002	-30,9	256,8	0,5858
$fup_4(x) \cdot D^3(x)$	0,4246	-31,3	240,3	0,623
$fup_4(x) \cdot D_{3.5}(x)$	0,3988	-30,9	255,5	0,5907
$fup_6^2(x) \cdot G_2^2(x)$	0,3769	-30,5	266,3	0,572
$fup_6(x) \cdot G_3(x)$	0,386	-30,7	259,9	0,5833
$fup_6^2(x) \cdot G_3(x)$	0,3611	-30,2	255,9	0,5522

Results

Experimental results measured in the implemented radar processing model presented in figure 5, let us to conclude that the Kaiser-Bessel function gets the highest selectivity among classical windows due to its better resolution performance of the near targets. Also, it is easy to see that novel windows based on AF $up(x)$ and $\Xi_2(x)$ have realized the best results in terms of the side-lobes levels. All studied windows have shown similar results in the resolution ability of the multiple targets.

Figure 6 shows the pulse compression signal using some classical and atomic function windows in presence of noise with SNR=20 dB. The windows: Hamming, Kaiser-Bessel, $up(x)$, $\Xi_2(x)$, $Fup_4(x) \cdot D_3(x)$ were employed here. The best results are realized by AF $up(x)$, because this function presents the small side-lobes and good resolution. Another window that has good characteristics in the noise presence is $Fup_4(x) \cdot D_3(x)$, but the gain is smaller than for $up(x)$ function.

The maximum amplitudes of side lobes and width of main lobe at -6dB level have been

obtained during the experiments. These data are presented in the table 2, where one can see that Hamming window offers better resolution and does not increase the main lobe width, similar result obtained using $up(x)$ among the family of novel windows.

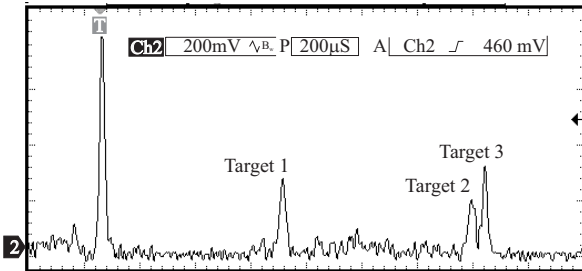

Figure 5 Real time hardware results in detection of the multiples targets

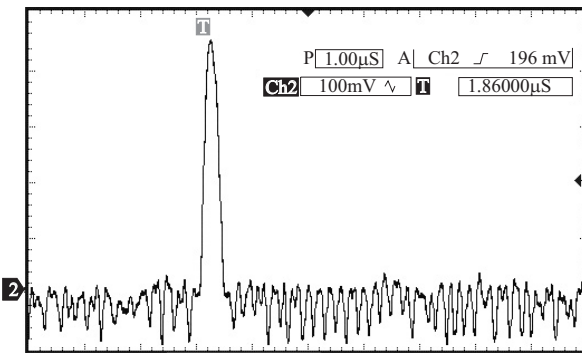

Figure 6 Main lobe in real time pulse compression for Blackman-Harris window in the presence of noise (SNR= 20dB)

Conclusions

This paper presents a comparative performance of different window functions applied during the pulse compression in radar. The best performance results have been obtained employing the atomic function window $up(x)$, which is characterized by better side-lobes levels in presence of noise, and small degradation in range resolution. With regard to classical windows the best windows are Hamming and Kaiser-Bessel, both with similar parameters.

The implementation of the compression-windowing techniques on FPGA in real time mode has confirmed the significant decreasing of the lateral lobes by better classical and AF windows. The performances of atomic functions used in this work have proven possible applications of the novel windows in the processing of radar data.

Table 2 Numerical hardware processing results

<i>Window</i>	<i>Sidelobe level (dB)</i>	<i>Width main lobe at -6dB (ηsec)</i>
Rectangular	-14,1	124
Blackman 4 term	-31,8	274
Blackman	-32	230
Chebyshev	-31,7	272
Hamming	-33,3	196
Hanning	-31,8	214
Kaiser-Bessel	-31,1	172
$g_k(x), k = 0.5$	-31	292
$g_k(x), k = 1$	-32,2	285
$fup_1(x)$	-29,2	259
$fup_{15}(x)$	-30,5	570
$fup_6(x)$	-29,8	356
$\Sigma_2(x)$	-31,2	294
$\Sigma_5(x)$	-29,2	383
$Up(x)$	-29,8	258

Future research work requires additional investigations in the performance of parameters during the windowing procedure, and also in testing novel windows in frequency domain using FPGA.

Acknowledgements

The authors thank the National Polytechnic Institute and CONACYT of Mexico (project 81599) for its support.

References

1. F. E. Natashon, J. P. Reilly, M. N. Cohen. *Radar design principles*. 2nd ed. Ed. Scitech Publishing. Inc. 1999. Mendham (NJ). pp. 583-632.
2. M. I. Skolnik. *Radar Handbook*. 2nd ed. Ed. Mc Graw Hill. 1990. New York. pp. 10.1-10.37.
3. E. Escamilla-Hernández, V. Ponomaryov, A. Ikuo, H. Endo. "Uso de FPGA para realizar compresión del pulso de radar". *Científica*. Vol. 9. 2005. pp. 73-81.
4. A. H. Nuttall. "Some windows with very good sidelobe behavior". *IEEE Trans. on acoustic, speech and signal processing*. Vol. 29. 1981. pp. 84-91.
5. F. J. Harris. "On the use of window for harmonic analysis with the DFT". *IEEE Processing*. Vol. 66. 1978. pp. 51-83.
6. V. F. Kravchenko. "New synthesized windows". *Doklady Physics*. Vol. 47. 2002. pp 51-60.
7. F. Gomeztagle, V. Kravchenko, V. Ponomaryov. "Super-Resolution Method Based on Wavelet Atomic Functions in Images and Video Sequences". *Telecommunications and Radio Engineering*. Vol. 68. 2009. pp.747-761.
8. V. Ponomaryov, E. Escamilla, V. Kravchenko. "Windowing technique in FM radar by FPGA for better target resolution". *SAR Image Analysis, Modeling and Techniques VIII*, Stockholm (Sweden). SPIE Europe. 2006. pp. 63630F-1 63630F-12.
9. V. Kravchenko, M. Basarab. "A New Method of Multidimensional-Signal Processing with the Use of R Functions and Atomic Functions". *Doklady Physics*. Vol. 47. 2002. pp. 195-200.
10. http://www.xilinx.com/publications/matrix/DSP_selection_guide1.pdf. Consultada el 20 de septiembre de 2008.
11. E. Antelo, J. Villalba, E. Zapata. "Low-Latency Pipelined 2D and 3D CORDIC Processors". *IEEE Trans on computer*. Vol. 57. 2008. pp. 404-417.